

# GRAVELLY OWNERS MANUAL

40" ROTARY MOWER  
3 BLADES  
MODEL NUMBER: 20062E1  
FORM NUMBER: 20976L2 (4-75)

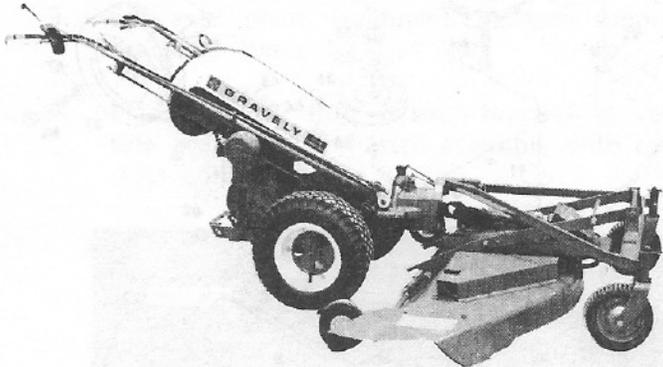

40" ROTARY MOWER WITH 7.6 CONVERTIBLE GRAVELLY



40" ROTARY MOWER WITH 812 RIDING GRAVELLY

## GENERAL

1. The 40" Rotary Mower is a center-mount unit designed and built to give many years of excellent service. With use of the quick hitch and front mount kits, it can also be used with Convertible Gravelys. The mower is recommended for homeowner lawn care and will also handle light weed mowing: has rugged deck, drive, spindles and blades.
2. The Owners Manual includes set up, safety, operator and maintenance instructions. Use the illustrated parts list for reference to individual part numbers. Item numbers used in this manual are in reference to fig 1. Contact The Gravely Dealer for further information.
3. To continue its program of quality and design improvement, the manufacturer reserves the right to change specifications, design or prices without incurring obligation.

## 4. SPECIFICATIONS

Cutting Width: 40 inches

Total Width: 52 inches

Weight: 148 lbs.

Deck: Heavy steel stamping

Drive: Right angle bevel gears, tapered roller bearings, aluminum housing, self-adjusting spring tensioned V-belt

Spindle Assemblies: Tapered roller bearings, blade cradles

Blades: Steel, hi-strength, hi-lift, 13-3/4" length, .204" thick

Range of Adjustment: 3-1/8" (cutting height) from lowest to highest position.

Purpose: Homeowner Lawn Care

### Recommended Tractors:

All Single Cylinder Riding Gravelys, 10 hp and greater

All Convertible Gravelys, 7.6 hp and greater

### Convertible Gravelys require:

Quick Hitch Kit 11898E1

Front Mount Kit 15569E1

Rear wheels of riders must be inboard.

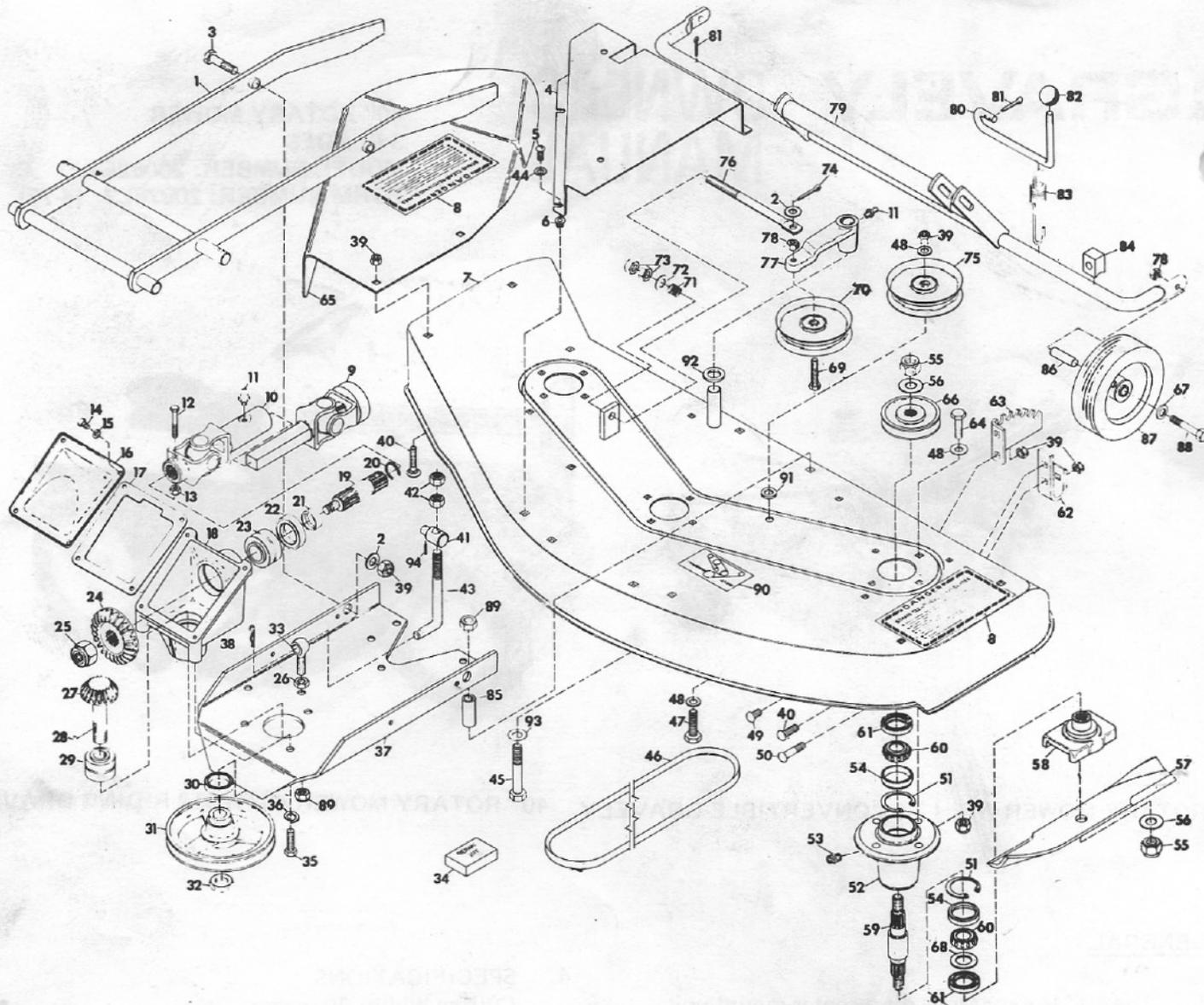

ITEM NO.	PART NO.	DESCRIPTION
1	19355A1	Arm, Pivot Weldment
2	120394	Washer, Flat 13/32 x 13/16 x .065
3	180126	Bolt, Hex 3/8-16 x 1-1/2
4	14674P2	Cover, Pulley R.H.
5	14675P2	Cover, Pulley L.H.
6	160536	Screw, Mach 1/4-20 x 5/8 Pan Hd
7	11777P1	Grommet, Plastic
8	20056A1	Deck, 40 In. Weldment
9	18549P1	Decal, Danger
10	19074P1	Shaft, Prop Sq. Bar
11	15518P1	Joint, U Female End
12	9411027	Fitting, Lube 1/4-28
13	180044	Bolt, Hex 1/4-20 x 2
14	419454	Nut, Lock 1/4-20 Washer Insert
15	180916	Bolt, Hex 1/4-20 x 1/2
16	120380	Washer, Lock 1/4 Sp.
17	10982P1	Cover, Gear Housing
18	11231P1	Gasket, Gear Housing
19	14636P1	Castings, Gear Box
20	20016P1	Shaft, Drive
21	14642P1	Ring, Retaining Reliance, Eaton #328
22	14641P1	Spacer, Ring
23	14646P1	Seal, Oil 1-1/4 x 1-63/64 x .437
24	14640A1	Bearing, Assembly 1.0000 x 1.9800 x 1.2430
25	20819P1	Gear, Bevel
26	456007	Nut, Lock 3/4-10 Washer Insert
27	120238	Nut, Jam 1/2-13
28	20820P1	Shaft, Gear Pinion
29	431787	Key, Woodruff 3/16 x 5/8 Hard No. 61
30	14644A1	Bearing, Assembly .7500 x 1.781 x 1.4990
31	14645P1	Seal, Oil 1-1/4 x 1-11/16
32	14660P1	Sheave, 1/2 x 6.50
33	451539	Nut, Jam 3/4-10 Hex Heavy
34	19350P1	Bolt, Eye
35	12134P1	Kit, Repair Universal Joint Rockwell Std.
36	20573P1	Kit, Repair Universal Joint Neapco 1605X
37	180173	Bolt, Hex 1/2-13 x 1
38	120384	Washer, Lock 1/2 Sp.
39	19351P1	Support, Gear Housing
40	15691P1	Pin, Hair Cotter
41	456004	Nut, Lock 3/8-16 Washer Insert Hex
42	120915	Bolt, 3/8-16 x 1 Rd. Hd. Sq. Nk.
43	11317A1	Pivot, Mower Lift Asm.
44	120238	Nut, Jam 1/2-13
45	19201P1	Rod, Lift
46	120392	Washer, Flat 9/32 x 5/8 x .065
47	180193	Bolt, Hex 1/2-13 x 3-3/4
48	14673P1	Belt, V 1/2 x 5/16 x 117
49	180129	Bolt, Hex 3/8-16 x 1-7/8
50	120388	Washer, Flat 7/16 x 1 x .083

ITEM NO.	PART NO.	DESCRIPTION
51	126227	Bolt, 3/8-16 x 3/4 Rd. Hd. Sq. Nk.
52	126419	Bolt, 3/8-16 x 2 Rd. Hd. Sq. Nk.
53	20059P1	Ring, Retaining MS000-200
54	20057P1	Housing, Spindle Bearing
55	20741P1	Fitting, Lube Safety Vent
56	9245P1	Bearing, Race
57	9418692	Nut, Lock 5/8-11 Washer Insert Hex
58	131016	Washer, Flat 21/32 x 1-5/16 x .095
59	14668P1	Blade
60	20066P1	Cradle, Blade
61	20058P1	Shaft, Spindle
62	9246P1	Bearing, Cones
63	20064P1	Seal, Oil 1.375 x 1.987 x .313
64	11264P1	Bracket, Axle Support
65	11265P1	Bracket, Height Adjust.
66	180124	Bolt, Hex 3/8-16 x 1-1/4
67	19986P1	Shield, Safety Extension, 40" Mower
68	20065P1	Sheave, Spindle
69	446477	Washer, Flat 7/16 x 1-3/8 x .083
70	20743P1	Washer
71	11313P1	Bolt, Drilled 3/8-16 x 1-3/4
72	11255P1	Sheave, Idler 11/16 x 4.62
73	11779P1	Spring, Comp Type 1 x .78 x 338 Rate
74	120395	Washer, Flat 15/32 x 15/16 x .065
75	271501	Nut, Hex 7/16-14
76	179252	Pin, Cotter 1/16 x 1
77	11316P1	Sheave, Idler 11/16 x 4.62
78	14671P1	Rod, Idler
79	10992P1	Arm, Idler Pivot
80	124829	Nut, Jam 3/8-16 Hex
81	14661A1	Axle, Pivot Weldment
82	10993P1	Lever, Height Adjust.
83	120123	Pin, Cotter 1/8 x 1-1/4
84	11261P1	Knob, Adj. Control
85	11268P1	Spring, Ext Type 4-3/8 x .87 x 45 Rate
86	11260P1	Stop, Nylon
87	19349P1	Spacer, .510 x .840 x 2.622
88	11937P1	Bushing, .385 x .750 x 2.593
89	11386P1	Wheel, Gaster
90	189305	Bolt, Hex 3/8-16 x 3-1/2
91	435507	Nut, Lock 1/2-13 Washer Insert Hex
92	11715P1	Decal, Bolt Installation
93	14672P1	Spacer, Idler
NS	14670P1	Spacer, Idler Arm
NS	120396	Washer, Flat 17/32 x 1-1/16 x .095
NS	142485	Pin, Groove 1/8 x 5/8 Type A
NS	20818A1	Drive, Assembly 40" Mower

fig 1 ILLUSTRATED PARTS LIST

## ASSEMBLY

1. If mower is to be mounted on a Riding Gravely (immediately after assembly) set mower on smooth pavement so the mower can be slid under The Gravely.
2. Raise and support rear of mower about 4 inches.
3. Set axle pivot weldment in axle support brackets, Items 62 and 79.
4. Place a nylon stop in each bracket, curved side against axle. Fasten assembly with carriage bolts and nuts.

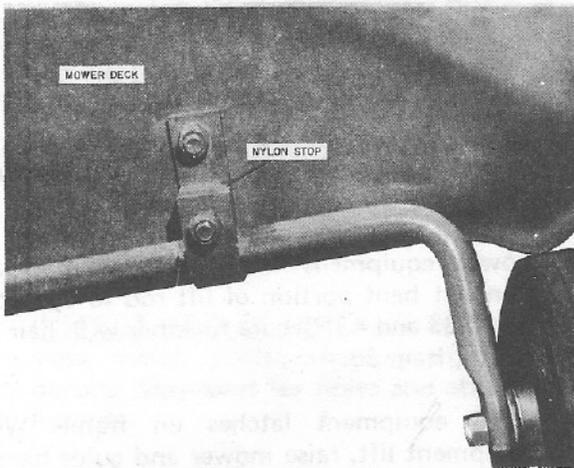

fig 2

5. Install a cotter pin in hole through axle just left of right side axle support. The cotter pin is not to interfere with the mower deck, fig 2.

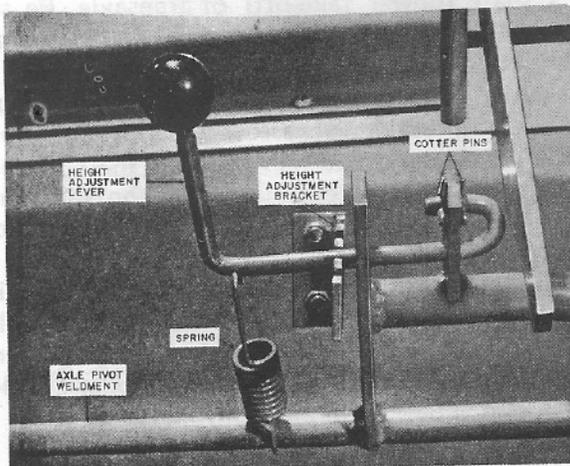

fig 3

6. Slide height adjustment lever in the 2 slots of the axle weldment. Fasten it with 2 cotter pins. Connect spring to height adjustment lever and axle. Screw knob on lever, fig 3.

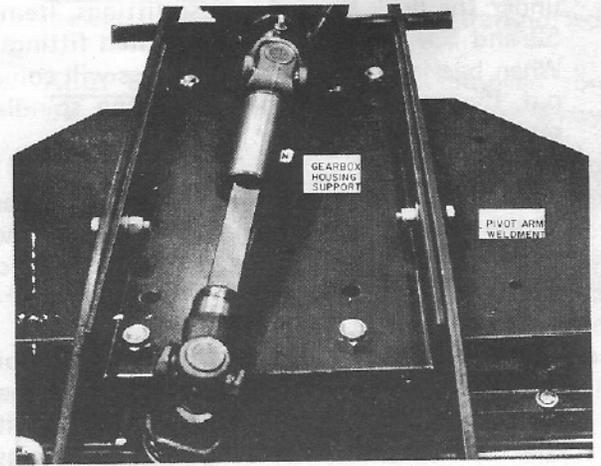

fig 4

7. Bolt pivot arm weldment to gearbox housing support; bolt heads outside, nuts and washers to the inside, fig 4.
8. Apply a light coat of general purpose grease to splined portion of gearbox drive shaft. Slide female end of the drive shaft universal joint onto the gearbox shaft. Be sure that bolt holes align. Fasten the "U" joint to gearbox shaft with bolt and locknut: Items 10, 12, 13 and 19 and fig 4.
9. To use mower with 400 series and Convertible Gravelys, modify drive shaft as shown on Form 19477P1 packed with mower (cut 5½ inches off end of rectangular male shaft).
10. Apply heavy coat of general purpose grease to rectangular male shaft. Slide it into female shaft. Wipe off excess grease. The mower is now ready for initial lubrication.

## LUBRICATION

1. There are 7 grease fittings on the mower. After initial lubrication each point is to be relubricated every 8 HOURS of operation or more often when used in severe dust and/or grit conditions.

Spindle bearing housings	-----	3
Idler pivot arm	-----	1
Drive shaft	-----	1
Gauge wheels	-----	2

Note: Before relubricating, wipe fittings clean so as not to force dirt into grease fitting.

2. Blade spindle bearings are lubricated from under the deck through grease fittings, Items 52 and 53. These are special vented fittings. When bearing housing is full, excess will come out the vent rather than rupturing spindle seals.
3. The idler pivot arm is lubricated from the rear of the deck through the grease fitting on the bushing. Add grease until it comes out around the stud, Items 70 and 77.
4. The drive shaft is lubricated from the top of the mower through the grease fitting on the female end "U" joint. Add grease until it comes out about the rectangular shaft, Items 9, 10 and 11, and fig 4.
5. Gauge wheels are lubricated through grease fittings on the wheel hubs. Add grease until it comes out around the bushing. Items 86 and 87.
6. The gearbox is prelubricated and only needs visual inspection. If signs of leakage are present, refill box to its capacity with general purpose grease. Do not damage gasket, Items 17 and 18.
7. FRONT MOUNT KIT: There are 5 grease fittings on the assembly. After initial lubrication each point is to be relubricated every 8 HOURS of operation or more often when used in severe dust and/or grit conditions.

Caster wheels -----	2
King pin weldments -----	2
Pivot pin weldment -----	1

## MOUNTING

### Riding Gravelys, Center Mounting

1. Slide lift pivot on lift rod with groove pin extended towards bend in lift rod, Items 41, 43 and 94.
2. Run one jam nut 3/4 of the way on threaded portion of lift rod. Keeping it in position, jam other nut tightly against it, Items 42 and 43.
3. Lower equipment lift all the way down. Turn lift rod upside down (bent portion up) and put lift pivot in second hole from the end of the lift weldment. Put it in from the left side, fig 5.
4. Rotate lift rod to right-side-up position (bent part down) and raise equipment lift all the way up.

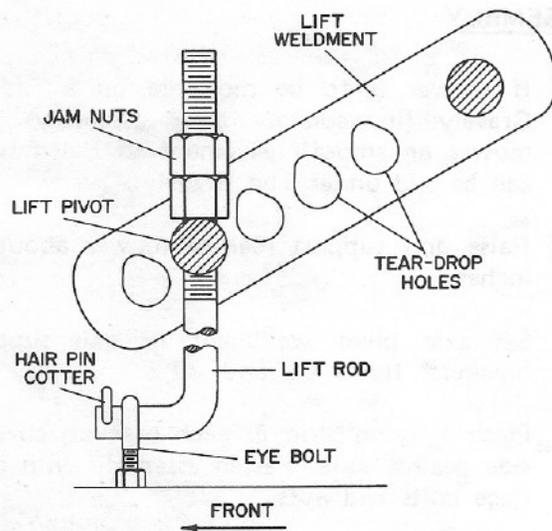

fig 5

5. Set height adjustment lever in lowest cutting position (most forward notch). Slide mower under the chassis.
6. Lower equipment lift all the way down. Connect bent portion of lift rod to eye bolt, Items 33 and 43. Secure together with hair pin cotter, Item 38.
7. Open equipment latches on frame. With equipment lift, raise mower and guide hanger assembly into the latches. Lock latches closed with hair pin cotters.
8. Lower mower all the way down. Apply a light coat of general purpose grease to splined PTO shaft. Connect drive shaft collar to PTO shaft (power take-off) of transaxle. Be sure collar "clicks" into position on PTO shaft.
  - A. Twist Type Collar: Rotate collar ring in direction of arrow on ring and hold. Slide collar half way on shaft. Release ring and continue sliding on shaft until collar "clicks" and locks in position.
  - B. Slide Type Collar: Slide collar ring towards "U" joint and hold. Slide collar half way on shaft. Release ring and continue sliding on shaft until collar "clicks" and locks in position.

### Convertible Gravelys, Front Mounting

9. Fasten quick hitch kit to Convertible Gravelly.
10. Apply light coat of general purpose grease to PTO shaft and pivot pin of quick hitch kit.

11. Connect front mount kit to pivot arm of mower.
12. Slide the pivot pin of the quick hitch into the front mount kit and secure with washer and "klik" pin.
13. Connect the drive shaft to the PTO shaft as in paragraph 8.
14. Lubricate front mount kit as described in LUBRICATION, paragraph 7.

## SAFETY

1. READ THE GRAVELY OWNERS MANUAL. Be familiar with all controls and follow the safety precautions outlined in the manual.
2. DO NOT ALLOW PASSENGERS to accompany the operator at any time.
3. DO NOT ALLOW CHILDREN to operate the equipment, nor allow adults to operate it without their having knowledge of safe operating practices.
4. INSPECT AND CLEAR work area of rocks, glass, metal, bones, and any other foreign objects. Stay alert for holes and other hidden hazards.
5. USE EXTREME CAUTION when operating on slopes.
  - A. Operator Riding: go up and down the face of slopes.
  - B. Operator Walking: go across the face of slopes.
6. REDUCE SPEED on all side slopes and sharp turns.
7. DO NOT OPERATE equipment except from proper operator's position on the seat of Riders or at handles of Convertibles.
8. KEEP SAFETY devices, interlocks, and shields in place at all times.
9. DISENGAGE POWER to mower and stop engine prior to making any adjustment or clearing the unit.
10. DO NOT WEAR loose fitting clothing or accessories that might get caught in moving parts or on the controls. Keep hands, feet, hair, clothing, etc., away from moving parts.

11. PUT THE PTO in the OUT position when the mower is not in use or is being transported.
12. KEEP BYSTANDERS and pets removed from the work area, and a safe distance away.
13. DIRECT DISCHARGE so as not to endanger life or property; such as people, pets, structures, cars, etc.
14. AFTER STRIKING a foreign object, stop the engine and put the PTO in the OUT position BEFORE inspecting for damage. Any damage must be repaired before restarting the equipment.

## ADJUSTMENTS

1. Cutting Height: Controlled with lever on left side of mower. On Riders, it is most easily adjusted when mower is in the transport (raised) position. Move lever forward for a low cut and backward for a high cut.
2. Lift Rod (Riders): To make mower come up higher when equipment lift is in highest position, move jam nuts closer to bend in lift rod. This adjustment should bring the mower up closer to the chassis and still allow the mower to "float" when all the way down.
3. Blade Removal
  - A. Remove mower from The Gravely and turn mower upside down.
  - B. Remove nuts, washers, and blades, Items 55, 56 and 57. Wedge a piece of wood between blade and deck to keep the blade from turning. It is not necessary to remove blade cradles.
4. Blade Installation
  - A. Set blades in cradles, Items 57 and 58. The lift portion of the blades points toward mower deck.
  - B. Put on washers and torque nuts to 25 ft. lbs. Similar tightness can be reached with any 8" length handle wrench when used by an average man. Wedge a piece of wood between blades and deck housing to keep blades from turning.

5. Belt Tension
  - A. Remove right side belt cover and loosen jam nut on the end of the rod, Items 73 and 76.
  - B. Tighten the other jam nut against spring leaving an .010" to .015" air gap between coils of spring (approximate thickness of a match pack).
  - C. Tighten end of jam nut against adjusting jam nut.
  - D. Replace belt cover.

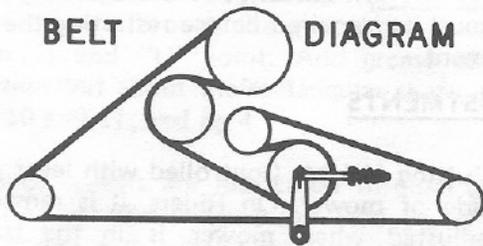

fig 6

6. Belt Replacement
  - A. Remove mower from The Gravelly and take off left and right belt covers.
  - B. Unbolt gear housing support from deck and remove old belt.
  - C. Put on new belt as per diagram on mower deck and loosen belt tension, fig 6.
  - D. Bolt gear housing support and left side belt cover back on deck.
  - E. Adjust belt tension and replace right side belt cover.

### OPERATION

1. Read The Gravelly Owners Manual. Follow safety and operating instructions to engage and disengage the PTO (power take-off).
2. After PTO is engaged, run engine at full throttle.
3. Select a ground speed fast enough to get the job done, yet slow enough to give a clean cut. Some trials may be necessary to find an optimum ground speed (for a particular stand of grass) to give a satisfactory cut.
4. In thick, Lush growth recude ground speed (not engine speed) to allow the mower enough (more) time to cut and discharge. Stop and shift to a lower gear to reduce ground speed.
5. NORMAL MOWING: Plan a mowing pattern so as to avoid discharging onto grass that has not been cut yet. Mowing grass with cuttings on top of it decreases the efficiency of the mower and is only necessary when mulching is desired. Keep the engine at full throttle.

6. MULCHING: Plan a mowing pattern so as to discharge cutting on grass that has yet to be mowed. The mower will then mow cut and uncut grass at the same time discharging a fine mulch. Slower ground speed is usually necessary for mulching than for normal mowing. Keep the engine at full throttle.

### ROUTINE MAINTENANCE

1. Perform all lubrications as described in LUBRICATION.
2. Check each spindle shaft nut before each operation to assure tightness; see ADJUSTMENT, paragraph 4.
3. Check all nuts and bolts every 24 HOURS of operation to assure tightness.

Note: Some nuts and bolts can be visually inspected for tightness but nuts such as the spindle nuts should always be checked with a wrench.

4. Inspect each blade for sharpness before each operation. Resharpen and balance them when they become dull. When blades are removed for sharpening, inspect for surface cracks. Discard any blade that has evidence of metal fatigue and/or cracks. Pay particular attention to the metal around the center hole.
5. Clear the mower of cuttings and debris. Do not allow build-up of cuttings and debris.
6. Inspect the gearbox drive for leakage before each operation. If signs of leakage are present, refill the gearbox with general purpose grease, Item 18. If there is significant leakage a repair should be made.
7. The following information if for identification of universal joints, Item 34 of fig 1, Illustrated Parts List.

Brand of Universal joints are identified by the end of the bearing cap.

Neapco =  = Repair Kit 20573P1

Rockwell =  = Repair Kit 12134P1

## REMOVAL

### Disconnecting Locking Collars

**TWIST TYPE:** Rotate collar ring in direction of arrow and pull collar off PTO shaft.

**SLIDE TYPE:** Pull on collar ring until collar comes off PTO shaft.

### RIDING GRAVELYS

1. As with mounting the mower on riding Gravelys, removal is most easily accomplished on smooth pavement.
2. With mower in transport position (fully raised) adjust cutting height to lowest position and open equipment latches.
3. Lower mower and disconnect lift rod from mower. Disconnect drive shaft from trans-axle.
4. Carefully, slide mower from under chassis. Remove lift rod and reconnect to mower for storage.

## CONVERTIBLE GRAVELYS

5. Disconnect drive shaft from quick hitch PTO
6. Remove "klik" pin and washer from pivot pin of quick hitch.
7. Pull The Gravely from the mower.
8. Put washer and "klik" pin back on pivot pin for storage.

## STORAGE

1. After removing mower from The Gravely, reconnect lift rod to mower so it won't be misplaced.
2. Clear mower of all cuttings and debris.
3. Perform all lubrications.
4. Apply a light coat of oil to preserve finish and appearance.

## WARRANTY

Gravely Tractors and Equipment are warrantied to be free from defective material and workmanship for a period of one year from date of purchase except when used for commercial purposes. Commercial use warranty is for a period of ninety (90) days from date of purchase.

Any defective part manufactured by Gravely will be replaced without charge provided such part is certified as defective by Gravely or by Gravely's expressly authorized representative.

## IMPORTANT PROVISIONS

The foregoing warranty is in lieu of all others and GRAVELY MAKES NO REPRESENTATION OR WARRANTY OF ANY KIND, EXPRESSED OR IMPLIED, AS TO MERCHANTABILITY, FITNESS FOR A PARTICULAR PURPOSE, OR ANY OTHER MATTER. IN NO EVENT SHALL GRAVELY BE RESPONSIBLE FOR CONSEQUENTIAL DAMAGES INCLUDING (BUT NOT LIMITED TO) INCONVENIENCE, RENTAL OR REPLACEMENT EQUIPMENT, LOSS OF PROFITS OR OTHER COMMERCIAL LOSS.

This warranty is not subject to change in modification by field representatives or Gravely dealers.

Certain components carry separate warranties by the manufacturer of such components. These components are subject to their manufacturer's warranties. Any claim, work or return of parts must be through an authorized Gravely dealer.

Service costs for transporting a unit to and from the dealer are the responsibilities of the customer. When such transportation is performed by the dealer, the dealer will charge the customer the usual rate for such service.

It is the dealer's responsibility to mail the "Warranty Card" to the manufacturer within fourteen (14) days after date of purchase to ensure prompt handling of any warranty claim.



1 Gravely Lane, Clemmons, N.C. 27012